

This Issue

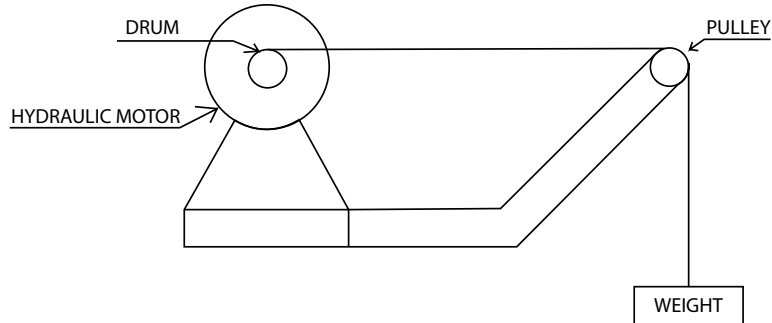

Illustration: John Spisak

Problem: Hydraulic motor

The hydraulic system contains a hydraulic motor rated at 1000 PSI, which contains a 10-radius drum turning at a speed of 30-rpm to lift a weight of 1000-pounds. Please determine the flow rate in units of gpm and the output horsepower of this 100% efficient motor.

- Pressure = 1000 PSI
- Drum radius = 10 inches
- Rpm = 30
- Weight = 1000 lbs.
- Hydraulic motor efficient = 100%



The teaser is posted on the IFPS website (www.ifps.org) and also printed in the Fluid Power Journal. Submit your information via the website, or fax it to 856-424-9248 attn: Donna Pollander. The deadline to submit an answer is the 15th of the month following release of the Journal. Anyone who submits the correct answer before the deadline date will have his/her name printed in the Society Page newsletter and in Fluid Power Journal. The winner will also be entered into a drawing for a special gift.

Don't Just Measure | Take Control

with Gems Rugged Pressure Switches



- Select from General Purpose, Vacuum, Differential & Specialty types
- Choose field-adjustable or factory set
- Unique piston/diaphragm design
- High proof pressures, yet sensitive & accurate
- Set points from 2 to 6000 PSI
- Wide variety of housing and diaphragm materials. Most are NEMA4 or NEMA 4X rated

OHV | Medical | Oil & Gas | Water | HVAC | Marine | Transport | Food & Beverage



OUR EXPERIENCE

YOUR SOLUTION



Pressure Switches

Vacuum, Differential
Specialty & General Purpose

take control today **800-378-1600** ■ GemsSensors.com

Use the space below to calculate your solution:

Previous Solution: Pneumatic Actuator Flow-rate Requirements

$$Q_1 = \pi/4 \times 22^2 \times (12 \times 2) \times 200 / 1728$$

$$= 8.72 \text{ ft}^3/\text{min}$$

Cylinder at 100-psig

$$Q_1 = P_2 Q_2 / P_1 = 114.7 \times 8.72 / 14.7$$

$$= 68.0\text{-Scfm}$$

Last Issue Winners:

Winner: \$40.00
IFPS Store Credit

Allan Pavalko
CFPS
SMC Corporation of
America
Richfield, OH

Answered Correctly:

Ernie Parker
CFPAI, CFPMM, CFPMT,
CFPS, CFPCC
Hennepin Technical College
Eden Prairie, MN

David Dunmire
CFPPS
Rocket Eye, Inc.
Sagamore Hills, OH

Tom Welle
Alexandria, MN

max G Series flow meters

Our flow meters perform better
than any flow meter you've used.



Max meters give you;

- Better accuracy
- Wider operating range
- Faster response with higher resolution

Find out more at: www.maxmachinery.com

Max Machinery, Inc.
maxmachinery.com

33 Healdsburg Avenue
Healdsburg, CA 95448

T: +1 707.433.2662
F: +1 707.433.1818